

## HYDROSPHERE TECHNOLOGIES, LLC™



### BRACKET SPECIFICATIONS

PART NUMBER	DESCRIPTION	HOUSING TO USE	CASE QUANTITY	BOX DIMENSION	WEIGHT (LBS)
HFB-25W	WHT. BRKT. 2.95"W x 4.5"D x 2.3"H	HFH25	100	11X11X4	38
HFB-45W	WHT. BRKT. 4.5"W x 6.9"D x 5.15"H	HFH45	20	9X9X6	45
HFB-252	WHT. BRKT. DOUBLE, BEND DOWN	HFH25	10	14X10X6	14
HFB-253	WHT. BRKT. TRIPLE, BEND DOWN	HFH25	10	19X10X6	33
HFB-452	WHT. BRKT. DOUBLE, BEND DOWN	HFH45	10	14X10X7	49
HFB-453	WHT. BRKT. TRIPLE, BEND DOWN	HFH45	5	24X10X7	48



### FILTER WRENCHES

PART NUMBER	DESCRIPTION	BOX QUANTITY
HFV-25	FILTER WRENCH FOR HFH25	150
HFV-45	FILTER WRENCH FOR HFH45	100



### FLOWLOK™ LEAK DETECTOR

PART NUMBER	DESCRIPTION	BOX QUANTITY
HFL-KIT	1/4" SHUTOFF VALVE, TRAY, 2 FELT PADS	20
HFL-PAD	FLOWLOK™ EXPANSION PAD	8



### SOLENOID VALVES

PART NUMBER	DESCRIPTION	QUANTITY EA.	A LENGTH	B WIDTH	C HEIGHT	D THREAD
HSBV-38110V	3/8" FPT NORMALLY CLOSED 110V	1	2.55"	1.85"	3.66"	3/8"
HSBV-12110V	1/2" FPT NORMALLY CLOSED 110V	1	2.60"	1.85"	3.66"	1/2"
HSBV-34110V	3/4" FPT NORMALLY CLOSED 110V	1	2.83"	2.12"	3.94"	3/4"
HSBV-10110V	1" FPT NORMALLY CLOSED 110V	1	3.54"	2.75"	4.25"	1"

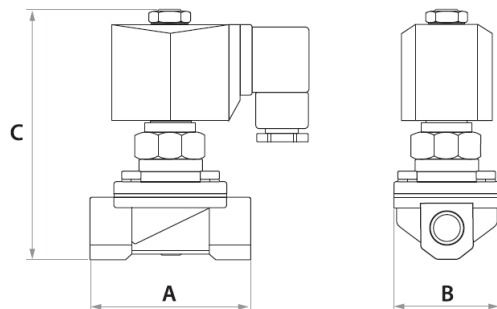

WARNING: Do not use with water that is micro-biologically unsafe or of unknown quality without adequate disinfection before or after the system.

Distributed by: